



## SELF PROPELLED OVERSEEDER Owner's Manual

OS901SPHD

Beginning Serial #: 021218001

### Accessories

CHARIOT KIT
Allows the user to ride behind the unit and decrease fatigue from walking.
P/N 351601

### Replacement Parts

REEL KIT
Use to replace worn or damaged reels.
P/N 351621

BLADE KIT
Use to replace worn or damaged blades on the reel.
P/N 351622

Original Instructions

IMPORTANT- READ CAREFULLY BEFORE USE AND KEEP FOR FUTURE REFERENCE



## CONTENTS

SPECIFICATIONS AND SAFETY	3
INSTRUCTION LABELS	4
PACKING CHECKLIST	5
ASSEMBLY	6
OPERATION	7-8
MAINTENANCE & TROUBLESHOOTING	9-10
PARTS LIST	11-22

NOT FOR REPRODUCTION



## OSSP Owner's Manual

### SPECIFICATIONS

#### OS901SPHD

Engine: HP'	9.0 HP (6.7kW)
Engine: Model	GX270UTQA2
Engine: Type	Honda
Engine: Fuel Capacity	5.6 qt. (5.3 L)
Engine: Oil Capacity	1.16 qt. (1.1 L)
Total Unit Weight:	323# (147 kg)
Max. operating slope	20°

### SAFETY



**WARNING**



This product can expose you to chemicals including gasoline engine exhaust, which is known to the State of California to cause cancer, and carbon monoxide, which is known to the State of California to cause birth defects or other reproductive harm. For more information go to [www.P65Warnings.ca.gov](http://www.P65Warnings.ca.gov).



# OSSP Owner's Manual

## INSTRUCTION LABELS

The labels shown below were installed on your BILLY GOAT® Overseeder. If any labels are damaged or missing, replace them before operating this equipment. Item numbers from the Illustrated Parts List and part numbers are provided for convenience in ordering replacement labels. The correct position for each label may be determined by referring to the Figure and Item numbers shown.



**LABEL DANGER KEEP HANDS AND FEET AWAY**  
ITEM #145 P/N 400424

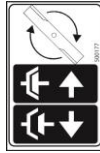

**LABEL CLUTCH ITEM #142**  
P/N 500177

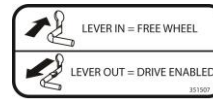

**LABEL TRANS. RELEASE**  
ITEM #146 P/N 351507



**LABEL CAUTION GUARDS**  
ITEM #133 P/N 900327

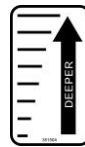

**LABEL DEPTH GAUGE**  
ITEM #59 P/N 351504

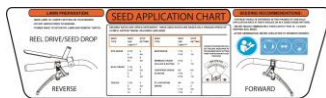

**LABEL INSTRUCTIONS SEEDER BOX**  
ITEM #56 P/N 351501  
(pg 12)



**LABEL SEED METERING**  
ITEM #66 P/N 351503  
(pg 12)

## ENGINE LABELS

### SUBARU

	Read the owner's manual.		
	Stay clear of the hot surface.		
	Exhaust gas is poisonous. Do not operate in an unventilated area.		
	Stop the engine before refueling.		
	Fire, open flame and smoking prohibited.		
	On (Run)		Plus: Positive polarity
	Off (Stop)		Battery
	Engine oil		Engine start (Electric start)
	Add oil		



### HONDA



READ OWN'S MANUAL BEFORE OPERATION  
 LIRE LE MANUEL UTILISATEUR AVANT USAGE  
 VOR INBETRIEBNAHME UNBEDINGT BEDIENUNGSANLEITUNG  
 NO UTILIZAR SINANTES NO HABEMANUAL  
HONDA MOTOR CO., LTD. MADE IN JAPAN

**OIL ALERT**

WHEN OIL LEVEL LOW, ENGINE STOPS IMMEDIATELY.



## OSSP Owner's Manual

### PACKING CHECKLIST

Your Billy Goat Overseeder is shipped from the factory in one carton.



**READ** all safety instructions before assembling unit.

**TAKE CAUTION** when removing the unit from the box, the Handle Assembly is attached to the unit and cables could snag.



**PUT OIL IN ENGINE BEFORE STARTING**

#### PARTS BAG & LITERATURE ASSY

Warranty card P/N- 400972

Owner's Manual P/N-351528

General Safety and Warnings Manual P/N-100295

Home Depot Quick Set-Up Literature P/N- 351529

Warranty Sheet P/N- 100305

Inner Pivot Shaft P/N- 351421

Hardware Kit P/N- 351349

Round Logo Label (3.5") P/N-100387

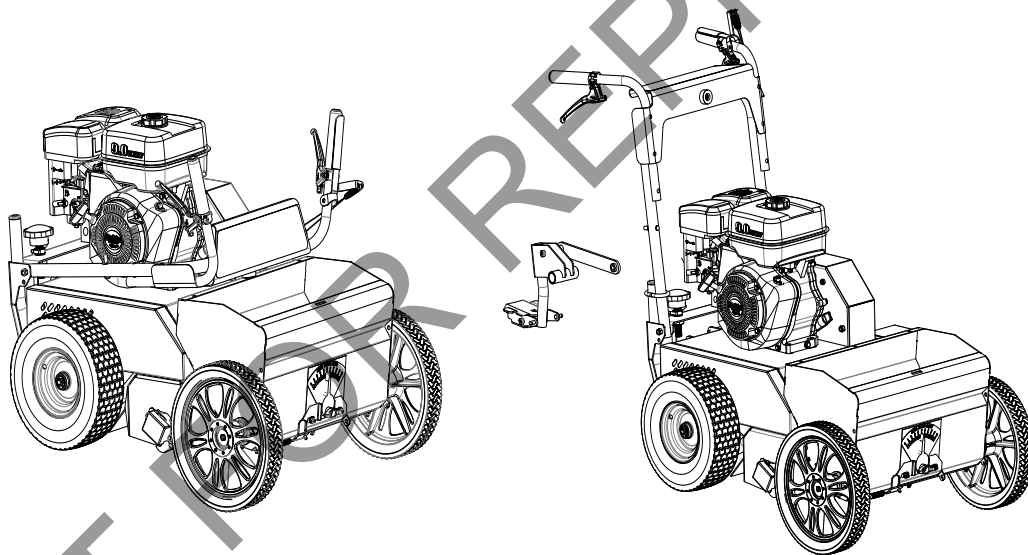

#### Boxing Parts Checklist

- Honda 9 OHV
- Parts bag P/N-351009
- Foot pedal assembly



## ASSEMBLY

*NOTE:* Items in ( ) can be referenced in the Parts Illustrations and Parts Lists on pages 11-22.

1. **UNFOLD** the upper handle and slide handle lock loops (item 35) into place to secure the upper handle to the lower.
2. **ATTACH** the bar of the foot pedal to the bracket located on the engine. Use the lock nut (item 93) from the parts bag.
3. **ATTACH** the pedal section to the rear of the frame between the two brackets by aligning the holes and inserting the tube (item 201) from the parts bag.
4. **TAP** the two pins (item 202) into both ends of the tube installed in step 3, and using pliers, spread the cotter pins to keep it from coming out.
5. **CHECK** engine oil level and fill to proper level with engine manufacturers recommended grade of oil. Make sure to adjust the machine so that the engine is level during checking. See engine manufacturers' instruction manual.
6. **CONNECT** spark plug wire.

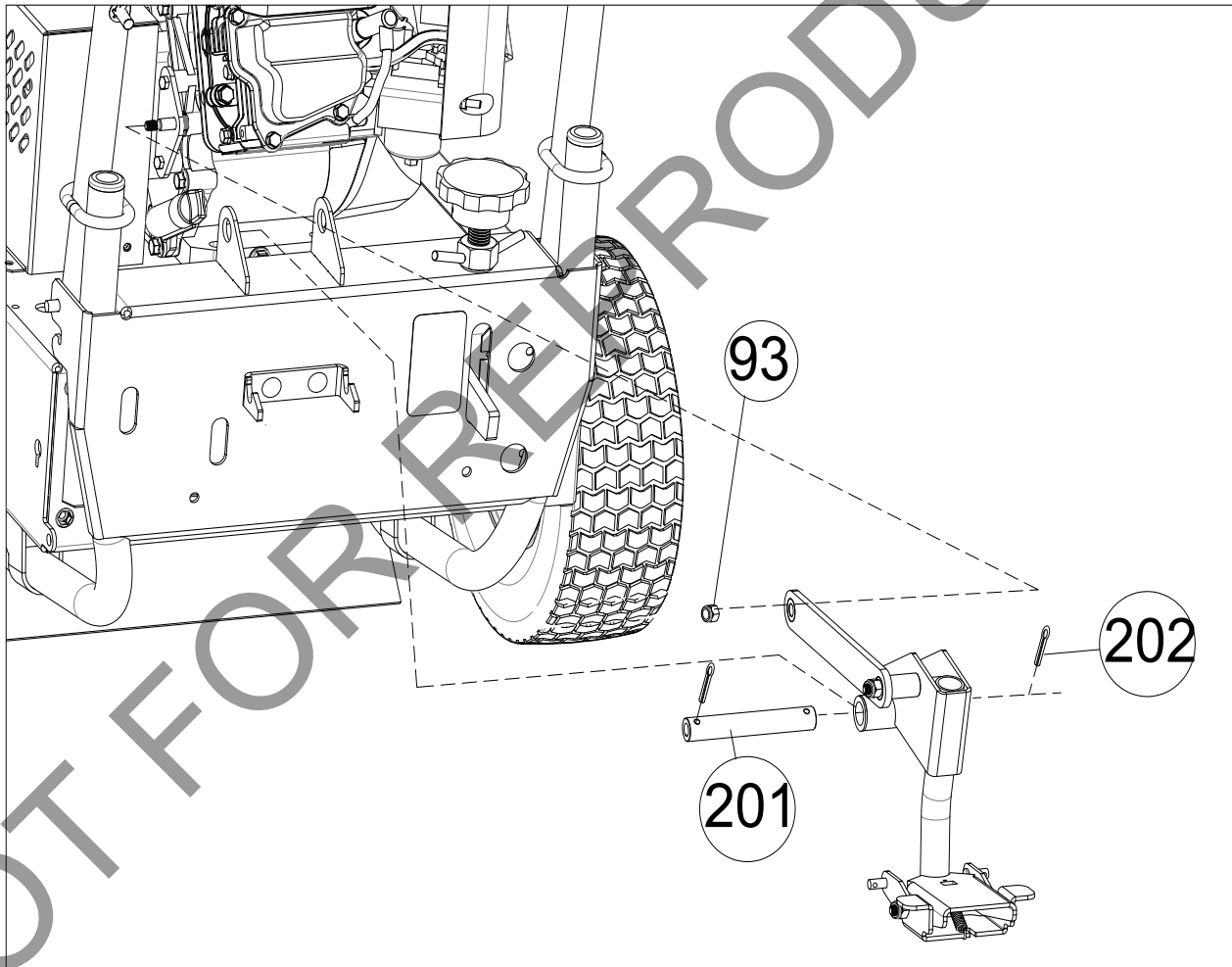



## OPERATION

*NOTE:* Items in ( ) can be referenced in the Parts Illustrations and Parts Lists on pages 11-22.

### FOLDING HANDLE

This unit is equipped with a folding upper handle for easier storage and transportation. The handle can be folded by sliding the handle lock loops (item 35) up. This releases the upper handle, allowing it to be folded over the unit.

### ADJUSTING BLADE DEPTH

The depth of the blades can be raised or lowered by rotating the knob located at the rear of the machine. The relative depth of the blades can be gauged by using the depth scale located on the rear of the machine and the bar next to it. (See Fig. 1)

### BLADE POSITION & DEPTH CONTROL LEVER

The blades can be raised or lowered into the ground by the height adjustment foot pedal at the rear of the unit. The blades will be in lowered position when the foot pedal is unlocked from the bracket and will be in transport position when the pedal is locked to the bracket. See Fig. 2 & 3 for operation. The resulting blade depth can be adjusted higher or lower.

Pressing on the outside tabs of the pedal will allow it to unlock from the bracket and lower into position. (See Fig. 2)

Pressing on the center of the pedal and pushing it into the bracket will allow it to be locked in transport position. (See Fig. 3)

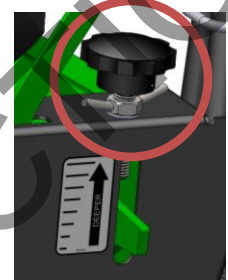

Fig. 1

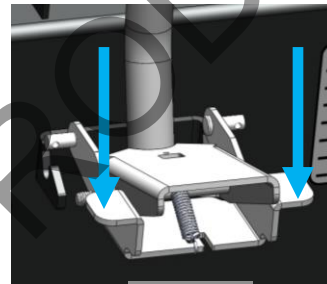

Fig. 2

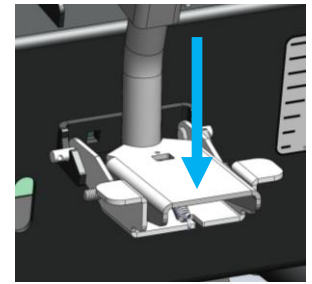

Fig. 3

### VERTI-CUTTING OPERATION

**SET DEPTH:** With engine off, set the raking depth so that the blades just touch on a flat surface (i.e. driveway, or sidewalk).

**ENGAGE BLADES:** Push the Reel Lever down on the operator handle (upper left side). *NOTE:* When engaging the blades in heavy load conditions (i.e. heavy thatch, or very uneven turf), push down on the operator handle lifting the front wheels slightly. Engage the blades. Slowly lower the unit into the turf.

**SLICE:** Verti-cut a small test area and examine the results. Some thatch and cut stems should be removed and deposited on top of the healthy grass. Grass runners should be cut and ready for removal. If excessive damage occurs to healthy grass, adjust the blade depth to decrease damage. Continue raking the yard, working in one direction (i.e. north-south, or east-west). *NOTE:* If a large drop in engine RPM occurs, or bounces during operation, the blade depth is set too low.

**REMOVE THATCH/STEMS:** After verti-cutting, a layer of thatch and cut stems will be deposited over the top of the lawn. We suggest the use of a lawn vacuum or wheeled blower for collection and removal of the thatch/stems.

### OVERSEEDING OPERATION

**DRY:** Be sure grass is dry. Wet conditions can cause increased damage to healthy grass.

**SEED:** Spread grass seed according to the seed suppliers directions (e.g. 10 lbs. per 1000 ft<sup>2</sup> [4.5 kg. per 93 m<sup>2</sup>]). Adjustments to the seed drop is located on the front of the unit on the seed dial and should be used in conjunction with the seed chart on the console.

**SET DEPTH:** With engine off, set the raking depth so that the blades reach 1/4"-1/2" (6-12 mm) below a flat surface (i.e. driveway, or sidewalk).

**ENGAGE REEL AND SEED DROP:** Push down on the reel lever on the operators handle. *NOTE:* When engaging the reel in heavy load conditions (i.e. heavy thatch, or very uneven turf), push down on the operators handle lifting the front wheels slightly. Engage the reel. Slowly lower the unit into the turf.

**SLICE:** Run machine over the area that has been seeded to incorporate the seed into the soil. If excessive damage occurs to healthy grass, adjust the blade depth to decrease damage. Continue raking the yard, working in one direction (i.e. north-south, or east-west). *NOTE:* If a large drop in engine RPM occurs, or bounces during operation, the blade depth is set too low.

**WATER/FERTILIZE:** After the seed has been worked into the soil, water and fertilize according to the seed supplier's directions.



## ADJUSTING SEED RATE

To set the seed flow rate, loosen the knob on the indicator dial and turn it to the corresponding stop setting on the seed application chart (below or on the console) for the type and amount of seed being used. (See Fig. 4)

**LAWN PREPARATION:**

- MOW LAWN TO LOWEST SETTING ON YOUR MOWER.
- DO NOT WATER PRIOR TO SEEDING.
- POWER RAKE TO DETATCH LAWN AND REMOVE THATCH.

**REEL DRIVE/SEED DROP**

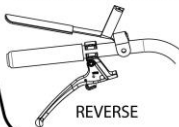

REVERSE

**SEED APPLICATION CHART**

SEEDING RATES ARE SPEED DEPENDENT. THESE SEED RATES ARE BASED ON A GROUND SPEED OF 3.5 MPH. FASTER TRAVEL DELIVERS LESS SEED.

SEED TYPE	RATE LBS./A.C.	STOP SETTING	SEED TYPE	RATE LBS./A.C.	STOP SETTING
RYE GRASS	2 1/2	4	BENTON GRASS	1 1/2	1
5	4.5			3 1/2	1.5
8 1/2	8		BERMUDA GRASS	2 1/2	1
10	10		SHALLOO BOWEN	4	1.5
BLUE GRASS	1 1/2	2	CENTAUPE GRASS	3 1/2	0.5
1 1/2	2.5		(COATED)	1 1/4	1
4	5			2 1/2	1.5
6	7.5				
FESCUE	3 1/2	4	ST. AUGUSTINE	3 1/2	1.5
5	4.5		GRASS	1	2
8	9			1 1/2	2.5
10	12			1 1/2	3

LOOK FOR THE WIDE ORANGE SET THE DIAL INDICATOR TO THE CORRESPONDING STOP SETTING TO OBTAIN THE BEST SEED DISTRIBUTION.



**SEEDING RECOMMENDATIONS:**

- FOR BEST RESULTS OVERSEED IN TWO PASSES OF ONE-HALF APPLICATION RATE AT RIGHT ANGLES OR IN A CROSS CROSS PATTERN.
- WATER HEAVILY IMMEDIATELY THEREAFTER FOR 10-14 DAYS KEEPING SOIL MOIST.
- AFTER COMPLETION, WATER LESS OFTEN TO PROMOTE GROWTH.



FORWARD

INSTRUCTION LABEL P/N 351501

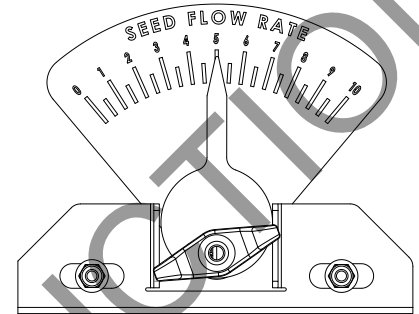

Fig. 4

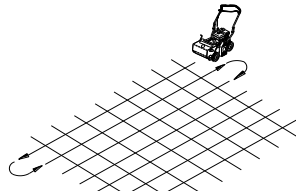

Fig. 5

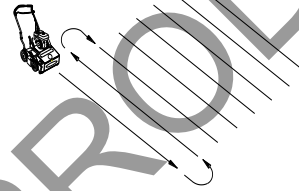

Fig. 6

### \*\*\*\*\*TIPS\*\*\*\*\*

Before beginning, it is best to evaluate the condition of the lawn by cutting one or more core samples from area to be treated. A core can be cut using a piece of PVC, or metal pipe. Hammer the pipe into the ground, remove it, push the core out of the pipe and inspect it to determine the depth of thatch in your yard.

#### MOW

Mow the lawn to its normal cut height. Be sure grass is dry. Wet conditions can cause increased damage to healthy grass.

#### INSPECT

Check the lawn before beginning work. Remove all rocks, wire, string, or other objects that can present a hazard during work.

#### IDENTIFY

Mark all fixed objects to be avoided during work, such as sprinkler heads, water valves, buried cables, or clothes line anchors, etc.

#### THATCH

Thatch is a dense layer of dead grass, clippings, and roots that builds up over time at the base of the lawn preventing air, water, and fertilizer from reaching the soil. This can cause shallow root development and make a lawn more susceptible to drought and disease. Thatch also provides an ideal environment for insects to hide and multiply. Periodic removal of thatch will keep your lawn in good health.

#### HEAVY THATCH

Lawns with an excessive amount of thatch will require multiple treatments for effective removal. Trying to remove excessive thatch (greater than 3/4" [19 mm] deep) in one treatment will damage or destroy the living part of the lawn. It is best to remove heavy thatch in seasonal treatments (i.e. spring, and fall).

#### SLOPES

Rake slopes across not up and down the slope. This is much easier and safer for the operator and is better for the lawn. Raking across will help to reduce runoff during watering and allow the sloped ground to hold more seed, fertilizer, and water. The unit's maximum operating slope is 35% or 19°.

#### DEPTH

The wide range of depth adjustment on your unit is provided to allow for blade wear. Setting the reel deeper will not produce better results. The flail reel is intended to be set so it just touches the surface on flat ground. The slicing reel should be set even with the ground for verti-slicing work, and set to a maximum 1/2" depth for overseeding. Setting the reel deeper will only result in premature wear on the unit (i.e. failed belt). If you desire to work the ground deeper than the above guidelines, it should be done gradually in multiple passes.

**SLICING / OVERSEEDING:** Mow the lawn to shorter than the normal cut height before starting (i.e. approximately 2" tall for fescue grass). For the best result, slice/overseed in single pass pattern (See Fig. 5 & 6).





## MAINTENANCE

NOTE: Items in ( ) can be referenced in the Parts Illustrations and Parts Lists on pages 11-22.

### PERIODIC MAINTENANCE

Periodic maintenance should be performed at the following intervals:

Maintenance Operation	Every Use (daily)	Every 25 Hours
Inspect for loose, worn or damaged parts		•
Check engine oil	•	
Inspect belts		•
Engine (See Engine Manual)		
Grease bearings		•
Inspect and clean engine air filter	•	
Oil height adjustment linkage		•

### SLICING BLADE WEAR

1. Wait for engine to cool and disconnect spark plug.
2. Close fuel valve on engine (if available).
3. Lean unit back onto lower handles and secure in place.
4. Inspect blades for wear and immediately replace any deformed or cracked blades. Measure the overall diameter of the blade.
5. If blades are warped or are no longer sharp, they must be replaced. NOTE: We recommend replacing all the blades at once.

### ENGINE BELT REPLACEMENT

1. Wait for engine to cool and disconnect spark plug.
2. Place the rear of the unit on blocks.
3. Remove the right rear tire (item 11) and spring (item 155) attaching the housing to the frame.
4. Remove three screws (item 114) holding the belt guard (item 19) in place.
5. Remove the four screws (item 107) holding the mule drive assembly (item 60) in place.
6. Remove the belt (item 14) by rotating the mule drive pulley and walking it out of the groove, and remove the mule assembly leaving the belt on the transmission.
7. Remove the carriage bolt and nuts holding the right bearing on the jackshaft. Do not remove the bearing and pulley.
8. Remove the belt guard (item 58) by removing the three screws (item 114).
9. Walk the belt off of the crankshaft pulley, and then slide it down the jackshaft to the bearing hole. This will allow the belt to be slid around the mule pulley.
10. Replace the belt by feeding it into the hole and around the pulley where the old one was removed. Make sure it is seated in the jackshaft pulley and then walk it onto the crankshaft pulley making sure it is inside the belt fingers.
11. Reattach the bearing and tighten the hardware securely.
12. Reattach the mule drive and belt, making sure that the belt is seated properly in the transmission pulley and the mule drive assembly.
13. Check the idler tension on the belt when the drive lever is engaged, if it is too loose, the spring (item 82) holding the idler arm will need to be replaced.
14. Reattach the guards, tire, spring and spark plug and make sure of proper operation.



## MULE BELT REPLACEMENT

1. Wait for engine to cool and disconnect spark plug.
2. Place the rear of the unit on blocks.
3. Remove the right rear tire (item 11) and spring (item 155) attaching the housing to the frame.
4. Remove (3) screws (item 114) holding the belt guard (item 19) in place.
5. Remove the four screws (item 107) holding the mule drive assembly (item 60) in place. This will allow access to the belt.
6. Remove the belt (item 14) by rotating the mule drive pulley and walking it out of the groove, and then sliding it off of the transmission. Discard old belt.
7. Install new belt using same procedure to walk the belt into the groove, making sure it is seated fully in all pulleys. Reattach the mule drive assembly.
8. With new belt installed, pull the drive levers up and make sure the idler pulley puts tension on the cable. The proper adjustment should have the drive lever fully engaged and the belt should be snug on the pulleys.
9. Re-install the belt guard, spring, and tire, then reattach the spark plug.

## REEL BELT REPLACEMENT

1. Wait for engine to cool and disconnect spark plug.
2. Remove two screws (item 38) holding the belt guard (item 20) in place.
3. Remove the belt (item 17) by rotating the reel pulley (item 16) and walking it out of the groove. Discard old belt.
4. Install new belt using same procedure to walk the belt into the groove, making sure that it is inside the belt fingers.
5. With new belt installed, push the reel drive lever down and make sure the idler pulley puts tension on the cable. The proper adjustment should have the blade lever fully engaged and the belt should be snug on the pulleys.
6. Re-install the belt guard and reattach the spark plug.

## TROUBLESHOOTING

Problem	Possible Cause	Solution
Abnormal vibration	Damaged or missing blades. Loose handle bolts. Loose engine bolts.	Stop work immediately. Replace any damaged or missing blades. Tighten all loose nuts and bolts.
Engine stalls or labors when raking	Blades set too deep into ground.	Raise blades so that they just touch the ground on a level surface.
Engine will not start	Stop switch off (Honda only). Throttle in off position. Out of gasoline or bad, old gasoline. Spark Plug wire disconnected. Gas valve off. Dirty air cleaner.	Check choke position. Check gasoline. Connect spark plug wire. Turn on gas valve. Clean or replace air cleaner. Contact a qualified service person.
Engine is locked, will not pull over	Debris locked against reel, or drive pulleys. Engine problem.	Pull spark plug wire and remove debris. Contact an engine servicing dealer for engine problems.



## SLICING REEL ASSY

P/N 351603

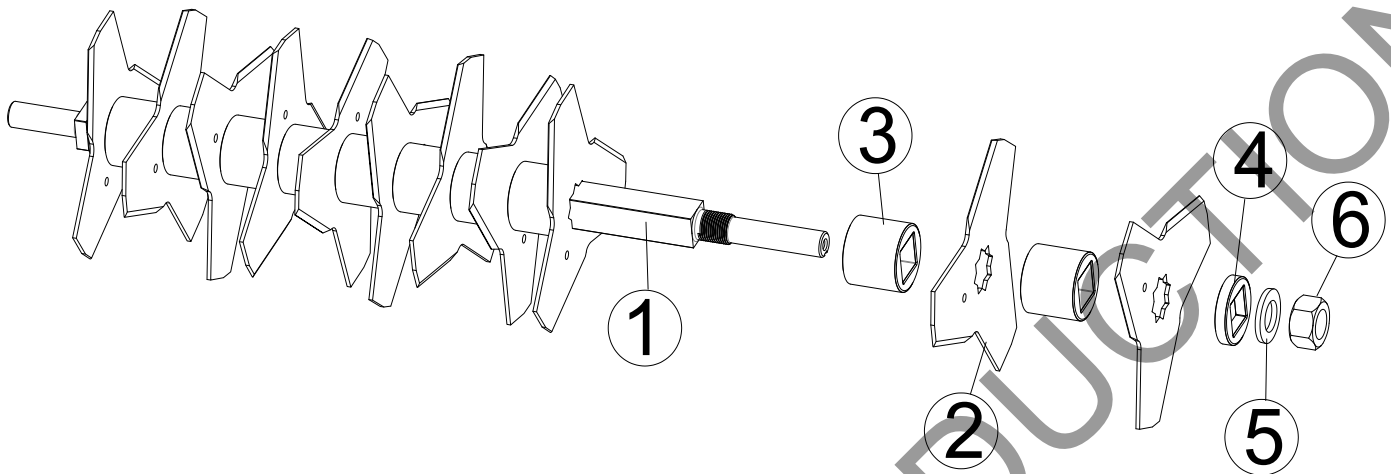

ITEM NO	DESCRIPTION	PART NO.	QTY
1	SHAFT VERTICUTTING REEL OS900SP	351111	1
2	BLADE, VERTICUT LASER CLAD	351290	11
3	SPACER PM REEL OS900SP	351261	10
4	SPACER HARDENED REEL OS900SP	351297	1
5	SPRING DISC 7/8" ID	351298	1
6	NUT 7/8"-14 NC	350341	1

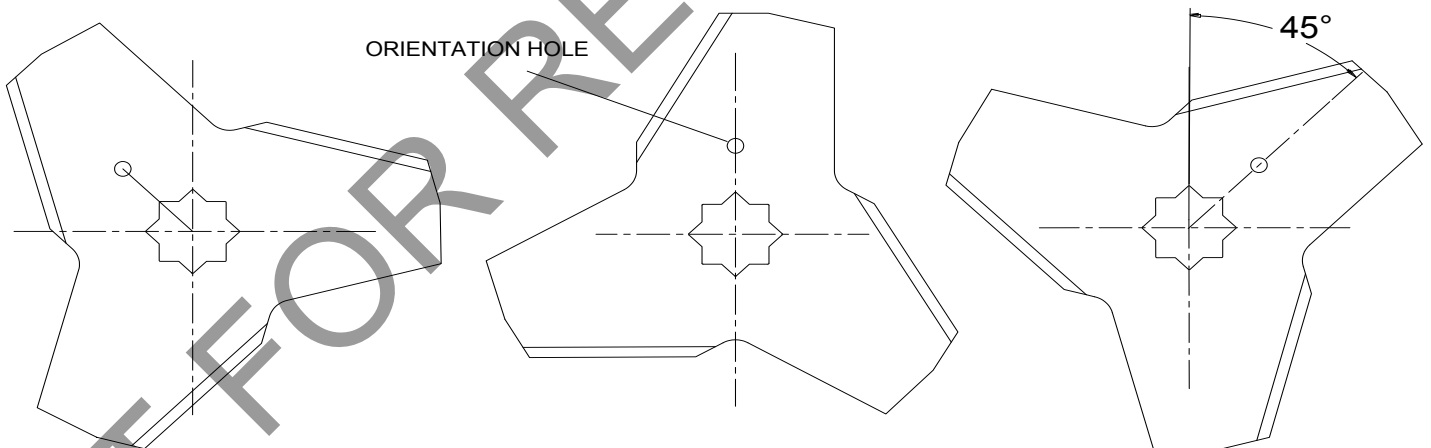

EACH BLADE SHOULD BE ROTATED CLOCKWISE 45 DEGREES. USE THE HOLE IN THE BLADE TO SET ORIENTATION.



## OSSP ENGINE ASSEMBLY PARTS DRAWING

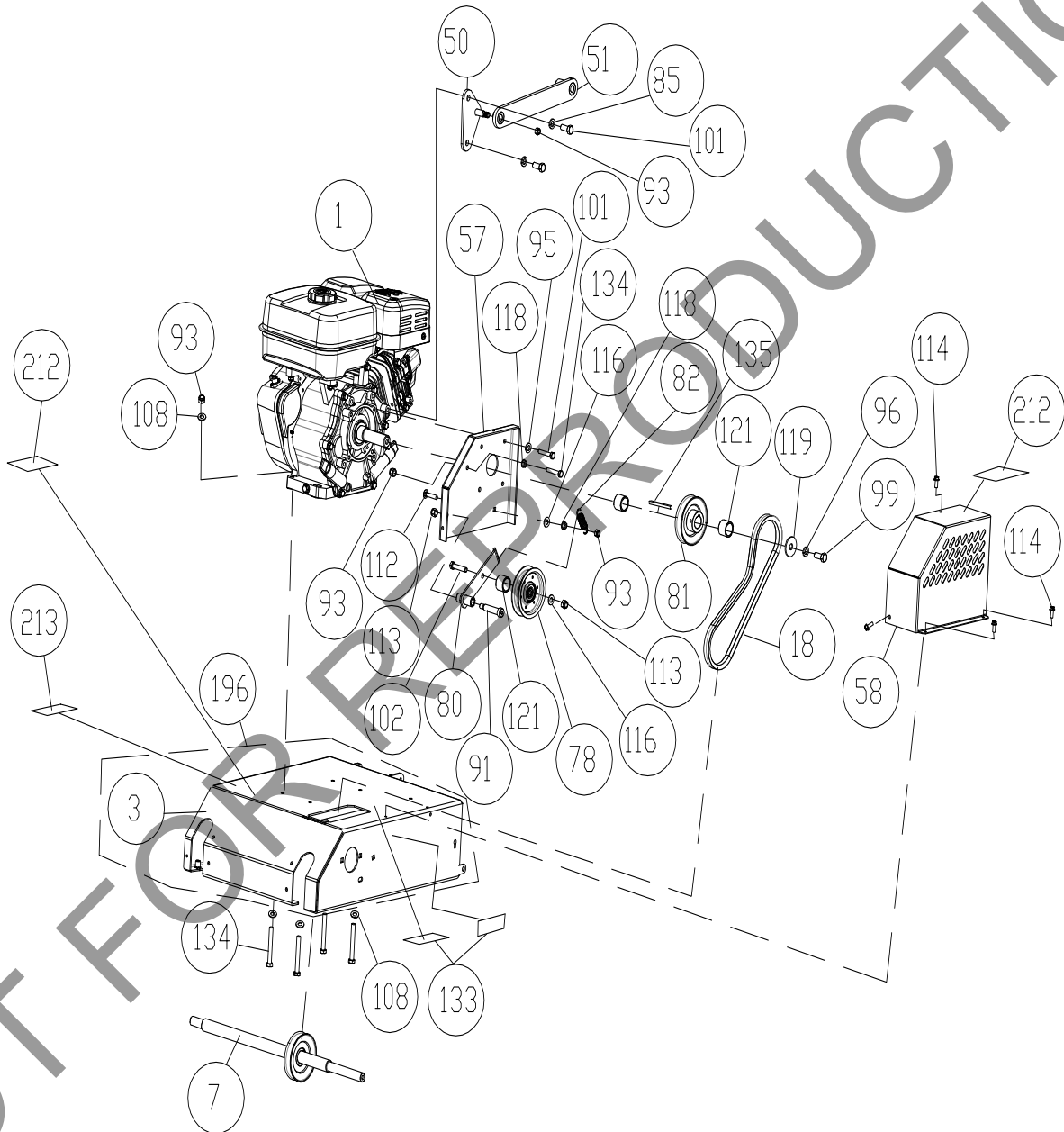



## OSSP Owner's Manual

### OSSP ENGINE ASSEMBLY PARTS LIST

ITEM NO.	DESCRIPTION	OS901SPHD	
		PART NO.	QTY
1	ENGINE HONDA 9HP	430287	1
	ENGINE SUBARU 9HP	-	-
3	ENGINE BASE WA	351125	1
7	JACKSHAFT WA	351107	1
18	BELT GATES #8954-0298	351211	1
50	ENGINE BRACKET WA	351121	1
51	LINKAGE FOOT CONTROL WA	351122	1
57	BRACKET GUARD BELT UPPER	351203	1
58	GUARD BELT UPPER OS900SP	351116	1
78	PULLEY IDLER 4" OD X 3/8 BORE	500113	1
80	ARM IDLER WA UPPER	351113	1
81	PULLEY 3.50" OD X 1.00" BORE	351296	1
82	SPRING IDLER UPPER	351275	1
91	BOLT SHOULDER 1/2" X 2"	520031	1
93	NUT LOCK 5/16"-18	8160002	7
95	WASHER SPLIT LOCK	8177011	6
96	WASHER LOCK 7/16" S/T MED	8177013	1
99	SCREWCAP 7/16"-20 X 1" HCS GR. 8 W/PATCH	510213	1
101	SCREWCAP 5/16"-24 X 1" GR 8 W/PATCH	400164	6
102	SCREWCAP 3/8"-16 X 1 3/4" HCS ZP	8041053	1
108	WASHER 5/16 FLAT	8171003	8
112	BOLT CARRIAGE 5/16"-18 X 1 1/2" ZP	8024042	1
113	LOCK NUT 3/8-16	8160003	2
114	SCREW SELF TAP 1/4"-20 X 5/8" HWH TYPE F	890359	3
116	WASHER 3/8" SAE	8172009	2
118	NUT FLANGE 5/16-18 ZP	350346	2
119	PLATE IMPELLER WASHER PB110	850443	1
121	SPACER 1.25 OD X 1.010 ID X .938 THK	351413	2
133	LABEL DANGER	900327	2
134	SCREWCAP 5/16"-18 X 1 3/4" HCS ZP	8041031	5
135	KEY SQ 1/4" X 1"	9201113	1
196	ENGINE BASE WA OS900SP W/LABELS	351612	1
212	LABEL THD CLEANING FEE 2.00" X 4.00"	501525	2
213	LABEL, HD TOOL RENTAL 2" X 4"	351512	1



## OSSP REEL/REEL DRIVE ASSEMBLY PARTS DRAWING

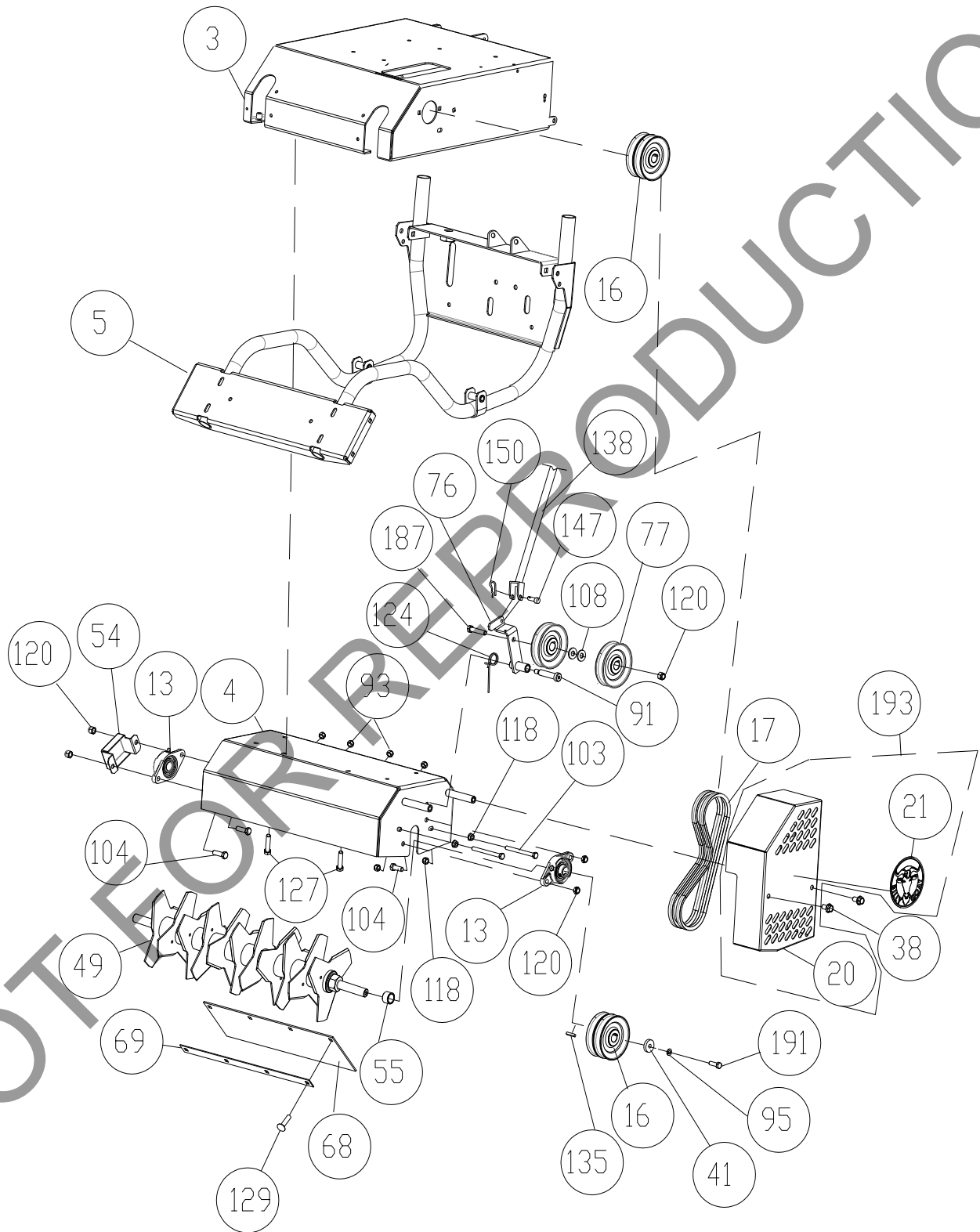



## OSSP Owner's Manual

### OSSP REEL/REEL DRIVE ASSEMBLY PARTS LIST

ITEM NO.	DESCRIPTION	OS901SPHD	
		PART NO.	QTY
3	ENGINE BASE WA	351125	1
4	HOUSING VERTICUTTER WA OS900SP	351101	1
5	FRAME SUPPORT OS900SP WA	351126	1
13	BEARING 3/4" CAST FLANGE W/ZERK	350209	2
16	PULLEY 0.75" ID X 4" 4L SECTION	351210	2
17	BELT 4L	351213	2
20	GUARD REEL BELT OS900SP	351117	1
21	LABEL DECAL SM CIRCLE	890456	1
38	SER HEX WASHER 3/8" - 16	791080	2
41	WASHER 1.125 OD X .344 ID X 10 GA	441150	1
49	REEL ASSY OS900SP	351621	1
54	GUARD BEARING REEL OS900SP	351206	1
55	SPACER SEED BOX AXLE OS900SP	351408	1
68	DEFLECTOR RUBBER OS900SP	351269	1
69	BAR CLAMP DEFLECTOR	351268	1
76	ARM IDLER WA REEL ENGAGE	351112	1
77	PULLEY	350114	2
91	BOLT SHOULDER 1/2" X 2"	520031	1
93	NUT LOCK 5/16"-18	8160002	4
95	WASHER SPLIT LOCK	8177011	1
103	SCREWCAP 5/16-18 X 3 1/2"	8041038	2
104	SCREWCAP 3/8"-16 X 1"	8041050	4
108	WASHER 5/16" FC	8171003	2
118	NUT FLANGE 5/16-18 ZP	350346	4
120	NUT LOCK 3/8-16 LT WT THIN ZP	8161042	5
124	SPRING IDLER MULE DRIVE	351295	1
127	SER HEX WASHER FLNG SCREW 5/16"-18 X 3/4"	351264	6
129	BOLT CARRIAGE 5/16"-18 X 3/4" ZP	8024039	4
135	KEY 3/16" SQ X 1 1/4"	9201080	1
138	CABLE CLUTCH SEEDING CONTROL	351221	1
147	PIN CLEVIS 1/4" X .50"	440124	1
150	PIN CLIP HITCH 0.051" X 3/4"	440193	1
187	SCREWCAP 3/8"-16 X 2 1/2" ZP	8041056	1
191	SCREWCAP 5/16"-24 X 1" GR.8 ZP W/PATCH	400164	1
193	GUARD REEL BELT OS900SP W/LABELS	351607	1



## OSSP HANDLE ASSEMBLY PARTS DRAWING

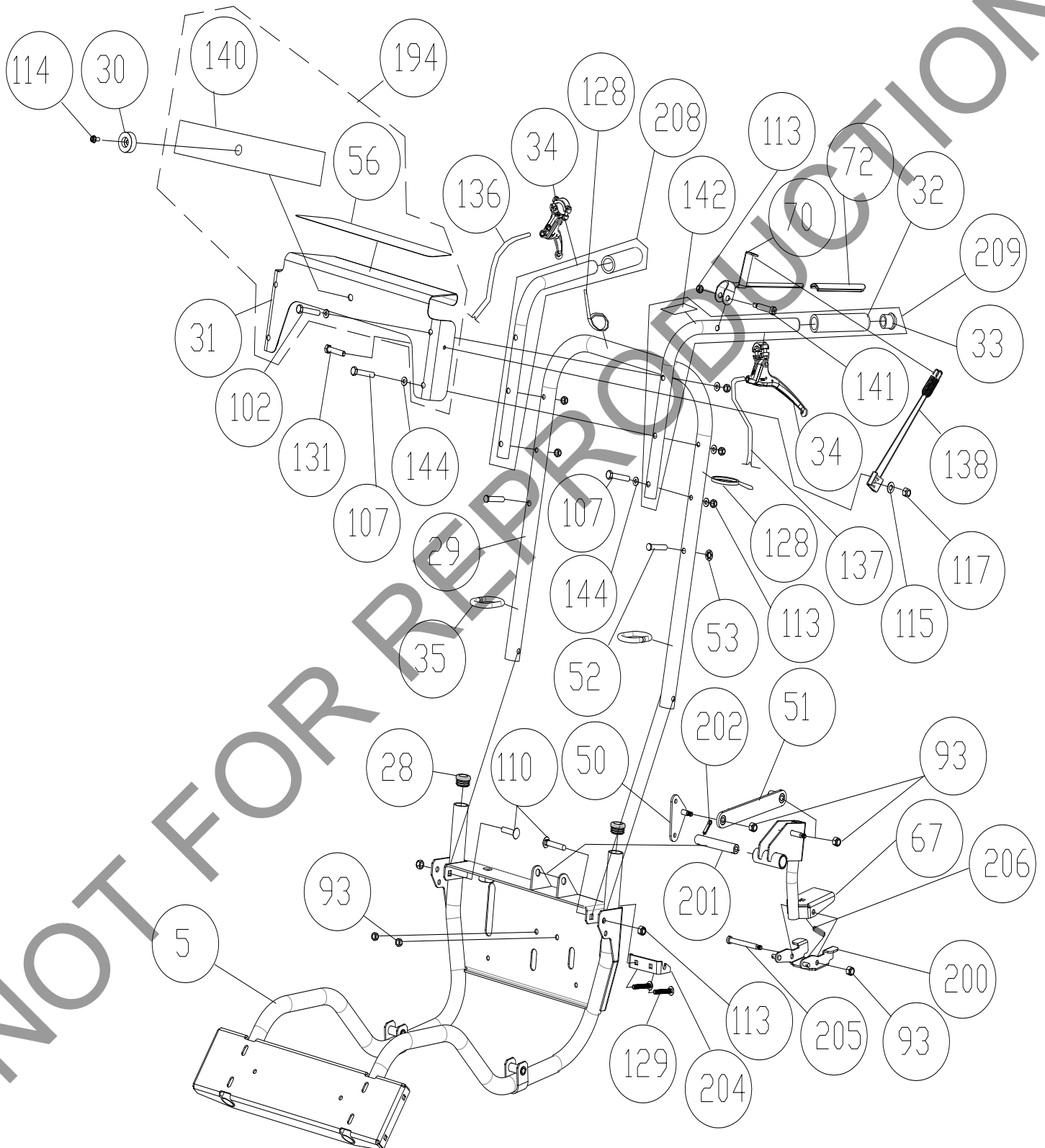





## OSSP Owner's Manual

### OSSP HANDLE ASSEMBLY PARTS LIST

ITEM NO.	DESCRIPTION	OS901SPHD	
		PART NO.	QTY
5	FRAME SUPPORT OS900SP WA	351126	1
28	PLUG TUBE INSERT 1.25 OD	791056	2
29	HANDLE FOLDING OS900SP	351406	1
30	BUMPER RECESS	360298	1
31	BRACKET CONSOLE OS900SP	351208	1
32	GRIP HANDLE	500267	2
33	PLUG TUBE INSERT 1" OD	890132	2
34	CONTROL MAGURA OS900SP	351209	2
35	LOOP FOLDING HANDLE	351231	2
50	ENGINE BRACKET WA	351121	1
51	LINKAGE FOOT CONTROL WA	351122	1
52	PIN CLEVIS 3/8 X 2.125	520120	2
53	RETAINER 3/8" BOLT PUSH NUT	360279	2
56	LABEL INSTRUCTION OS900SP	351501	1
67	PEDAL SERVICE KIT	351615	1
70	LEVER CLUTCH/SEED DROP	351212	1
72	GRIP LEVER 0.125" X 1" X 5" ORANGE	500379	1
93	NUT LOCK 5/16"-18	8160002	5
102	SCREWCAP 3/8"-16 X 1 3/4" HCS ZP	8041053	2
107	SCREWCAP 3/8"-16 X 3" HCS ZP	8041058	4
110	BOLT CARRIAGE 3/8"-16 X 2" ZP	8024062	2
113	LOCK NUT 3/8-16	8160003	9
114	SCREW SELF TAP 1/4"-20 X 5/8" HWH TYPE F	890359	1
115	WASHER 1/4" SAE	8172007	1
117	LOCK NUT 1/4-20	8160001	1
128	TY WRAP	900407	2
129	BOLT CARRIAGE 5/16"-18 X 3/4" ZP	8024039	2
131	SCREWCAP 1/4"-20 X 1" HCS ZP	8041006	1
136	CABLE SPEED CONTROL RT	351219-S	1
137	CABLE SPEED CONTROL LFT	351271-S	1
138	CABLE CLUTCH SEEDING CONTROL	351221	1
140	LABEL LOGO OS900SP	351500	1
141	BOLT SHOULDER 3/8" X 1 1/4"	360284	1
142	LABEL CLUTCH BLADE	500177	1
144	WASHER 3/8 FC	8171004	12
194	BRACKET CONSOLE OS900SP W/LABELS	351605	1
200	RELEASE PEDAL WA	351124	1
201	SHAFT INNER PIVOT	351421	1
202	PIN COTTER 1/8" X 1" ZP	8197031	2
204	BRACKET PIN CATCH	351321	1
205	BOLT SHOULDER 3/8" DIA X 3.25 LG BLK OX	351316	1
206	SPRING PEDAL RELEASE	351309	1
208	HANDLE W/GRIP RIGHT OSSP SERVICE	351618	1
209	HANDLE W/GRIP LABEL LEFT OSSP SERVICE	351619	1





## OSSP SEED BOX ASSEMBLY PARTS LIST

ITEM NO.	DESCRIPTION	OS901SPHD	
		PART NO.	QTY
5	FRAME SUPPORT OS900SP WA	351126	1
6	SEED BOX WA	351103	1
10	FRONT WHEEL 14" ASSY	351013	2
12	BEARING & FLANGETTE ASSY	850232	4
27	AXLE SEED BOX	351223	1
44	WHEEL PADDLE SEED WA	351105	1
45	PLATE SEED CONTROL OS900SP	351220	1
46	BRACKET CONTROL SEED RATE	351222	1
48	SPRING EXTENSION .5 X 5.00	351303	1
55	SPACER SEED BOX AXLE OS900SP	351408	2
63	SPACER SEED PLATE OS900SP	351253	8
64	DIAL SEED INDICATOR	351265	1
65	KNOB 5/16"-18 X 5/8" FLUTED	400339	1
66	LABEL SEED FLOW RATE	351503	1
83	CLAMP ROUTING FUEL LINE	791070	1
100	SCREW 1/4" - 20 X .75 HWH	8041004	8
115	WASHER 1/4" SAE	8172007	8
117	LOCK NUT 1/4-20	8160001	8
125	NUT 5/16"-18 SER HEX WASHER FLN	350346	8
129	BOLT CARRIAGE 5/16"-18 X 3/4" ZP	8024039	8
138	CABLE CLUTCH SEEDING CONTROL	351221	1
145	LABEL WARNING OPEI	400424	1
147	PIN CLEVIS 1/4" X .61	350399	1
148	LABEL BADGING OS900SP	351505	1
149	WASHER LOCK 5/16" TWISTED TOO	430298	2
150	PIN CLIP HITCH 0.051 X 3/4"	440193	1
151	BOLT CARRIAGE 5/16"-18 X 1 1/4" ZP	8024041	1
152	SCREWCAP 5/16"-18 X 3/4" HCS ZP	8041026	2
153	NUT LOCK 5/16"-18 LT WT TH ZP	8161041	1
154	WASHER FENDER 5/16"	8172020	2
192	SEED BOX WAS OS900SP W/LABELS	351604	1
207	SEED BOX SERVICE KIT	351616	1
211	SEED BOX BONNET	351344	1



## OSSP TRANSMISSION ASSEMBLY PARTS DRAWING

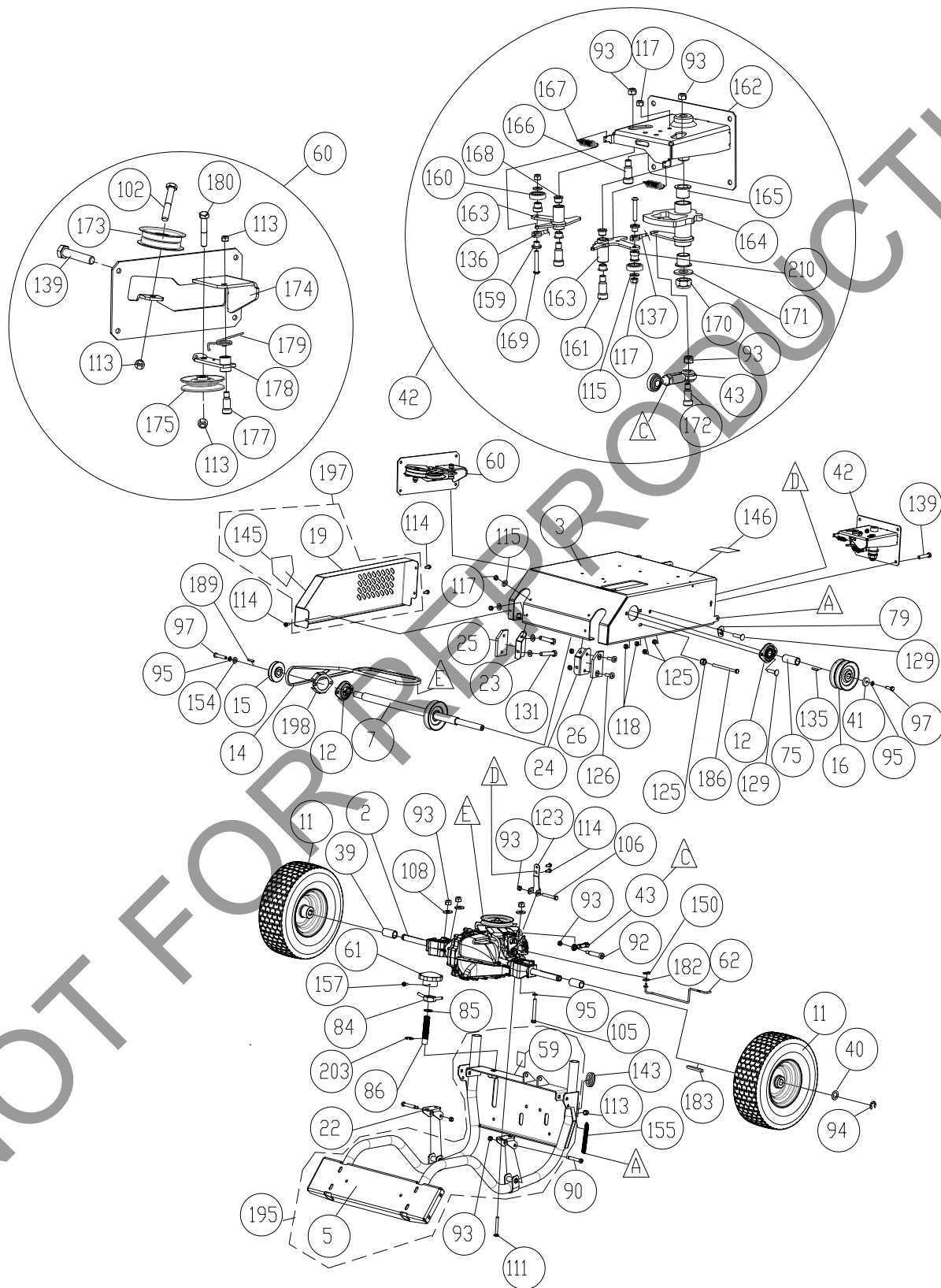



## OSSP TRANSMISSION ASSEMBLY PARTS LIST

ITEM NO.	DESCRIPTION	OS901SPHD	
		PART NO.	QTY
2	TRANSAXLE	351201	1
3	ENGINE BASE WA	351125	1
5	FRAME SUPPORT OS900SP WA	351126	1
7	JACKSHAFT WA	351107	1
11	REAR WHEEL 13" X 5" PNEU ASSY	351202	2
12	BEARING & FLANGETTE ASSY	850232	4
14	BELT 3L550 TRUFLEX	351327	1
15	PULLEY 0.75" ID X 3.50"	351325	1
16	PULLEY 0.75" ID X 4" 4L SECTION	351210	1
19	GUARD DRIVE BELT OS900SP	351118	1
22	BRACKET FIXED FRONT FRAME	351226	2
23	BRACKET RH WEAR PAD OS900SP	351227	1
24	BRACKET LH WEAR PAD OS900SP	351228	1
25	WEAR PAD RH OS900SP	351229	1
26	WEAR PAD LH OS900SP	351230	1
39	SPACER REAR WHEEL OS900SP	351409	2
40	WASHER .765 ID X 1.25 OD X .06 THK	850238	2
41	WASHER 1.125 OD X .344 ID X 10 GA	441150	1
42	SPEED CONTROL ASSY	351011	1
43	CONNECTOR SPEED CONTROL	351015	1
59	LABEL DEPTH GAUGE OS900SP	351504	1
60	MULE ASSY	351614	1
61	KNOB HAND	850154	1
62	ROD BYPASS ARM TRANSAXLE	351304	1
75	SPACER PULLEY JACKSHAFT	351415	1
79	BRACKET CLUTCH CABLE	351200	1
84	LOCKNUT WA	800227	1
85	WASHER .75"	800109	1
86	ROD HEIGHT ADJUST SCREW	351311	1
90	BOLT SHOULDER 3/8" X 2"	360153	2
92	BOLT SHOULDER 3/8" X 1/2"	830528	1
93	NUT LOCK 5/16"-18	8160002	10
94	RING RETAINING EXTERNAL 3/4"	850230	2
95	WASHER SPLIT LOCK	8177011	6
97	SCREWCAP 5/16-24 X 1"	400164	2
102	SCREWCAP 3/8"-16 X 1 3/4" HCS ZP	8041053	1
105	SCREWCAP 5/16"-18 X 3" HCS ZP	8041036	4
106	SCREWCAP 5/16"-18 X 2"	8041032	1
108	WASHER 5/16 FLAT	8171003	4
111	BOLT CARRIAGE 5/16"-18 X 2 3/4" ZP	8024047	4
113	LOCK NUT 3/8-16	8160003	4
114	SCREW SELF TAP 1/4"-20 X 5/8" HWH TYPE F	890359	5
115	WASHER 1/4" SAE	8172007	10
116	WASHER 3/8" SAE	8172009	2
117	LOCK NUT 1/4-20	8160001	6
118	NUT FLANGE 5/16-18 ZP	350346	4



## OSSP Owner's Manual

### OSSP TRANSMISSION ASSEMBLY PARTS LIST

ITEM NO.	DESCRIPTION	OS901SPHD	
		PART NO.	QTY
123	BRACKET TORQUE LIMITING	351294	1
125	NUT 5/16"-18 SER HEX WASHER FLNG ZP	350346	7
126	SCREW SPOT WELD 5/16"-18 X 3/4 W/PROJ	351263	4
129	BOLT CARRIAGE 5/16"-18 X 3/4" ZP	8024039	5
131	SCREWCAP 1/4"-20 X 1" HCS ZP	8041006	4
135	KEY 3/16" SQ X 1 1/4"	9201080	1
136	CABLE SPEED CONTROL RT	351219	1
137	CABLE SPEED CONTROL LFT	351271	1
139	SCREWCAP 5/16" SER HEX WSHR FLNG GR. 5 ZP	351264	8
143	GROMMET 1.25" HOLE	520092	1
146	LABEL DRIVE RELEASE OS900SP	351507	1
150	PIN CLIP HITCH 0.051 X 3/4"	440193	1
153	NUT LOCK 5/16"-18 LT WT TH ZP	8161041	1
154	WASHER FENDER 5/16"	8172020	1
155	SPRING LIFT ASSIST OS900SP	351254	2
157	SCREW MACH #10-24 X 2" HWF ZP	8059143	1
159	SPACER EYELET SPEED CONTROL PM	351348	2
160	BEARING 1/2" ID X 1.125 OD	351257	2
161	BOLT SHOULDER 3/8" X 1 3/4"	351258	2
162	BRACKET SPEED CONTROL WA OS900SP	351108	1
163	BELLCRANK SPEED CONTROL WA OS900SP	351109	2
164	CAM SPEED CONTROL WA	351110	1
165	BUSHING PIVOT FRAME AE	360183	2
166	BOLT SHOULDER 5/16" X 1 1/2"	500340	1
167	SPRING EXTENSION	800242	2
168	BUSHING 3/8" ID X 1/2" OD X 3/8"	840078	4
169	SCREWCAP 1/4-20 X 1 3/4 SKT BUT HD	840199	2
170	NUT LOCK 5/8"-11 LT WT TH ZP	8161046	1
171	WASHER 5/8" SAE	8172013	1
172	SCREWCAP 5/16"-18 X 1" HCS ZP	8041028	2
173	PULLEY IDLER 2.75" OD X 3/8" BORE	350114	1
174	BRACKET DRIVE BELT WA OS900SP	351104	1
175	PULLEY 3V GROOVE IDLER	351216	1
177	BOLT SHOULDER 1/2" X 2"	520031	1
178	ARM IDLER MULE DRIVE WA OS900SP	351120	1
179	SPRING IDLER MULE DRIVE OS900SP	351302	1
180	SCREWCAP 3/8"-16 X 1 1/2" HCS ZP	8041052	1
182	WASHER #10 SAE	8172005	1
183	KEY 3/16" SQ X 2 1/8"	9201087	2
186	SCREWCAP 5/16"-18 X 5" HCS ZP	8041042	1
189	KEY 3/16" SQ X 5/8"	9201072	1
195	FRAME SUPPORT OS900SP WA W/LABELS	351613	1
197	DRIVE BELT GUARD WA W/LABELS	351609	1
198	BRACKET BELT GUIDE OS900SP	351326	1
203	RING SNAP TRUARC	850233	1
210	SPACER STEPPED SPEED CONTROL PM	351347	2